



u-blox AG
Zürcherstrasse 68
8800 Thalwil
Switzerland
www.u-blox.com

Phone +41 1722 7444
Fax +41 1722 7447
info@u-blox.com

TIM-4H ANTARIS[®] 4 Programmable GPS Module with SuperSense[®]

Data Sheet

PRELIMINARY



Abstract

Technical description of the high sensitivity ANTARIS 4 GPS Module with SuperSense Indoor GPS in the industry standard form factor for use with passive and active antennas.

Data Sheet

your position is our focus

Title	TIM-4H		
Subtitle	ANTARIS® 4 Programmable GPS Module with SuperSense®		
Doc Type	Data Sheet	PRELIMINARY	
Doc Id	GPS.G4-MS4-05025-P5		
Revision Index	Date	Name	Status / Comments
P1	22. Sept 2005	GzB	Preliminary release
P2	31. Sept 2005	GzB	Disclaimer, section 1.3 and 4.2 (clarified power consumption)
P3	21. Dec 2005	GzB	Modified: Sections 1.3, 2, 3.3 (RESET_N), 4.2 (Vant)
P4	03. Feb 2006	GzB	Modified Section 1.3 and Table 4 (4 Hz update rate), Section 1.7, 6.2
P5	11. May 2006	GzB	Modified: Section 1.3, Table 3, Table 4 (Acquisition) Table 8, Table 9

We reserve all rights in this document and in the information contained therein. Reproduction, use or disclosure to third parties without express authority is strictly forbidden.

For most recent documents, please visit www.u-blox.com

Data Sheet Revisions	Identification of applicable hardware	Comments
P1 ... P5	All data codes	

	<p>Products marked with this lead-free symbol on the product label comply with the "Directive 2002/95/EC of the European Parliament and the Council on the Restriction of Use of certain Hazardous Substances in Electrical and Electronic Equipment" (RoHS).</p>
---	---

Semiconductor technology provided by ATMEL.

The specifications in this document are subject to change at u-blox's discretion. u-blox assumes no responsibility for any claims or damages arising out of the use of this document, or from the use of products and services mentioned in this document, including but not limited to claims or damages based on infringement of patents, copyrights or other intellectual property rights. u-blox makes no warranties, either expressed or implied with respect to the information and specifications contained in this document. u-blox does not support any applications in connection with active weapon systems, ammunition, life support and commercial aircraft. Performance characteristics listed in this document are estimates only and do not constitute a warranty or guarantee of product performance.

The copying, distribution and utilization of this document as well as the communication of its contents to others without expressed authorization is prohibited. Offenders will be held liable for the payment of damages. All rights reserved, in particular the right to carry out patent, utility model and ornamental design registrations.

u-blox, the u-blox logo, the TIM type GPS module, Antaris, SuperSense, "your position is our focus", NavLox, u-center, AssistNow, FixNow and EKF are (registered) trademarks of u-blox AG. The u-blox software as well as the design of the LEA type modules is protected by intellectual property rights in Switzerland and abroad. Further information available at info@u-blox.com. Copyright © 2006, u-blox AG

Contents

1	Functional Description	4
1.1	Overview	4
1.2	Block Diagram	4
1.3	Highlights	5
1.4	Features.....	5
1.5	Operating Modes.....	6
1.6	Protocols	6
1.7	Assisted GPS (A-GPS).....	6
1.8	Available Programming Resources (Preliminary Info)	7
1.9	Antenna	7
2	Performance Specification	8
3	Mechanical Specification	9
3.1	Dimensions.....	9
3.2	Specification	9
3.3	Pin Assignment.....	10
4	Electrical Specification	11
4.1	Absolute Maximum Ratings	11
4.2	Operating Conditions	12
5	Environmental Specification.....	13
6	Product Lineup	14
6.1	Default Settings	14
6.2	Ordering Information.....	14

1 Functional Description

1.1 Overview

The TIM-4H module combines high sensitivity with exceptionally low power consumption. The -158 dBm tracking sensitivity extends positioning coverage into places where GPS was not possible before, and enables solutions using smaller or covert antennas.

The successor to the TIM-LH module also shares the TIM-LH's 25.4 x 25.4 x 3 mm industry standard form factor initially created by u-blox. A 35% reduction in power consumption means extended battery time for portable, handheld devices. Finally, its small form factor and SMT pads are designed for fully automatic assembly processes with standard pick-and-place equipment and reflow soldering, enabling cost-efficient, high-volume production.

1.2 Block Diagram

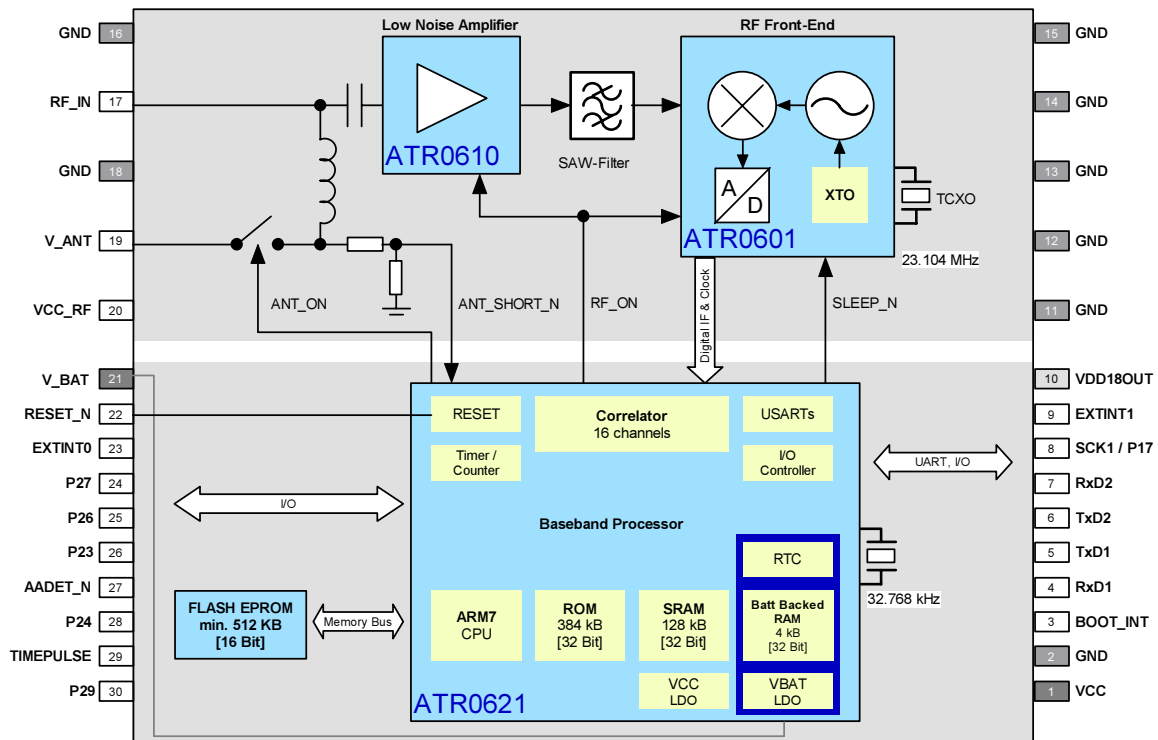

Figure 1: Block Diagram

1.3 Highlights

- **SuperSense® Indoor GPS**
- **Ultra low power consumption**
- **A-GPS and Autonomous GPS operation, AssistNow™ ready**
- **Flash EPROM: programmable and configurable**
- **4 Hz position update rate**
- **2 UART ports**

1.4 Features

- 16 channel ANTARIS 4 positioning engine
- Supports DGPS, WAAS, EGNOS and MSAS
- Power saving modes
- 5 μ A backup current
- Supports passive and active antennas
- Antenna short and open circuit detection and protection
- Power brown-out protection: No external reset hardware needed
- Operating temperature range: -40 to 85°C
- RoHS compliant (lead-free)

1.5 Operating Modes

The ANTARIS 4 GPS Technology supports following Operating Modes:

Operating Modes	Description
Continuous Tracking Mode (CTM)	In this mode, the Autonomous Power Management (APM) automatically optimizes power consumption. It powers off parts of the receiver when they are not used. Also, the CPU speed is reduced when the CPU workload is low.
Power Saving Modes	A configurable power saving mode is available where the GPS is put into sleep mode and activated up on a selectable time interval or upon external request (signal activity on serial port or EXTINT input). This mode is ideally suited in applications with stringent power budget requirements in mobile and battery operated end products.

Table 1: Operating Modes

For details, please refer to the *System Integration Manual for ANTARIS 4* [1].

1.6 Protocols

The TIM-4H supports different serial protocols. These can be assigned to any serial interface port.

Protocol	Type	Runs on
NMEA	Input/output, ASCII, 0183, 2.3 (compatible to 3.0) Standard \$GPxxx and u-blox-specific \$PUBX messages	All serial ports
UBX	Input/output, binary, u-blox proprietary	All serial ports
RTCM	Input, messages 1,2,3,9	All serial ports

Table 2: Available Protocols

For specification of the various protocols see the *Protocol Specification* [2].

1.7 Assisted GPS (A-GPS)

The ANTARIS 4 GPS engine supports both MS assisted (output of raw tracking information for position computation by the service provider) and MS based (accelerated acquisition and position computation in the GPS receiver) A-GPS. Supply of aiding information like ephemeris, almanac, rough last position and time and satellite status and an optional time synchronization signal will reduce time to first fix significantly.

1.8 Available Programming Resources (Preliminary Info)

Dedicated product variants of this GPS module are planned for use with customized software created with the ASK-4Q (ANTARIS 4 Software Customization Kit). Please contact u-blox for details.

Resources		Characteristics
Processor	ARM7TDMI running at 23 MHz	3.75 - 9 MIPS ¹ @ 1 Hz navigation update rate
Memory	Flash EPROM	Min 512 K Bytes (physical memory size for all code)
	SRAM	8 K Bytes
Interfaces	USARTs, synchronous and asynchronous operation	2 interfaces, 3 V levels, 5V tolerant
Digital I/Os	7 GPIOs	3 V levels, 5V tolerant
	2 interrupt-capable GPIOs	3 V levels, 5V tolerant (EXTINT0, EXTINT1)

Table 3: Available Programming Resources

1.9 Antenna

This GPS receiver is designed for use with passive and active antennas. An antenna supervisor is provided. If activated, the GPS receiver is capable of detecting short circuits to the active antenna by checking the bias voltage level and can shut down the voltage bias immediately. A series resistor is needed in front of the **V_ANT** input. UBX and NMEA messages are provided to report the condition of the antenna supply. Open circuit detection can also be supported with an additional external circuit. For details, please refer to the *System Integration Manual for ANTARIS 4* [1].

Parameter	Specification	
Antenna Type	Passive and active antenna	
Active Antenna Recommendations	Minimum gain	15 - 20 dB (to compensate signal loss in RF cable)
	Maximum noise figure	1.5 dB
	Maximum gain	50 dB
Antenna Supply	Using VCC_RF or external voltage source	
Antenna Supervisor	Short circuit detection	Built-in
	Open circuit detection	Enabled with external circuit

Table 4: Antenna Specification

¹ "VAX MIPS", calculated using Dhrystone, available for user code

2 Performance Specification

Parameter	Specification				
Receiver Type	L1 frequency, C/A Code, 16-Channels 8192 time / frequency search windows				
Max Navigation Update Rate	4 Hz				
Accuracy	Position	2.5 m CEP ³	5.0 m SEP ⁴		
	Position DGPS / SBAS ²	2.0 m CEP	3.0 m SEP		
Acquisition ^{5,6}	GPS Mode (UBX-CFG Msg):	Fast Acquisition Mode	Normal Mode	High Sensitivity Mode	Auto Mode
	Cold Start	34 s	36 s	41 s	34 s
	Warm Start	33 s			
	Hot Start	<3.5 s			
	Aided Start ⁷	5 s			
	Reacquisition	<1 s			
Sensitivity ⁸	Tracking	-158 dBm			
	Acquisition & Reacquisition	-148 dBm	Includes aided starts (A-GPS)		
	Cold Starts	-142dBm			
Accuracy of Timepulse Signal	RMS	50 ns			
	99%	<100 ns			
	Granularity	43 ns			
Dynamics	Strong signals	≤ 4 g			
	Weak signals	typ. 1 g			
Operational Limits (COCOM)	Altitude	18,000 m			
	Velocity	515 m/s			
	One of the limits may be exceeded but not both.				

Table 5: Performance Specification

² Depends on accuracy of correction data of DGPS or SBAS service

³ CEP = Circular Error Probability: The radius of a horizontal circle, centered at the antenna's true position, containing 50% of the fixes.

⁴ SEP = Spherical Error Probability. The radius of the sphere, centered at the true position, contains 50% of the fixes.

⁵ The different start-up modes like cold, warm and hot start are described in the System Integration Manual [1]

⁶ Measured with good visibility and -125 dBm signal strength

⁷ Time synch. signal from aiding source must be supplied to **EXTINT0** or **EXTINT1** pin, having accuracy of better than 200 μs

⁸ Demonstrated with a good active antenna

3 Mechanical Specification

3.1 Dimensions

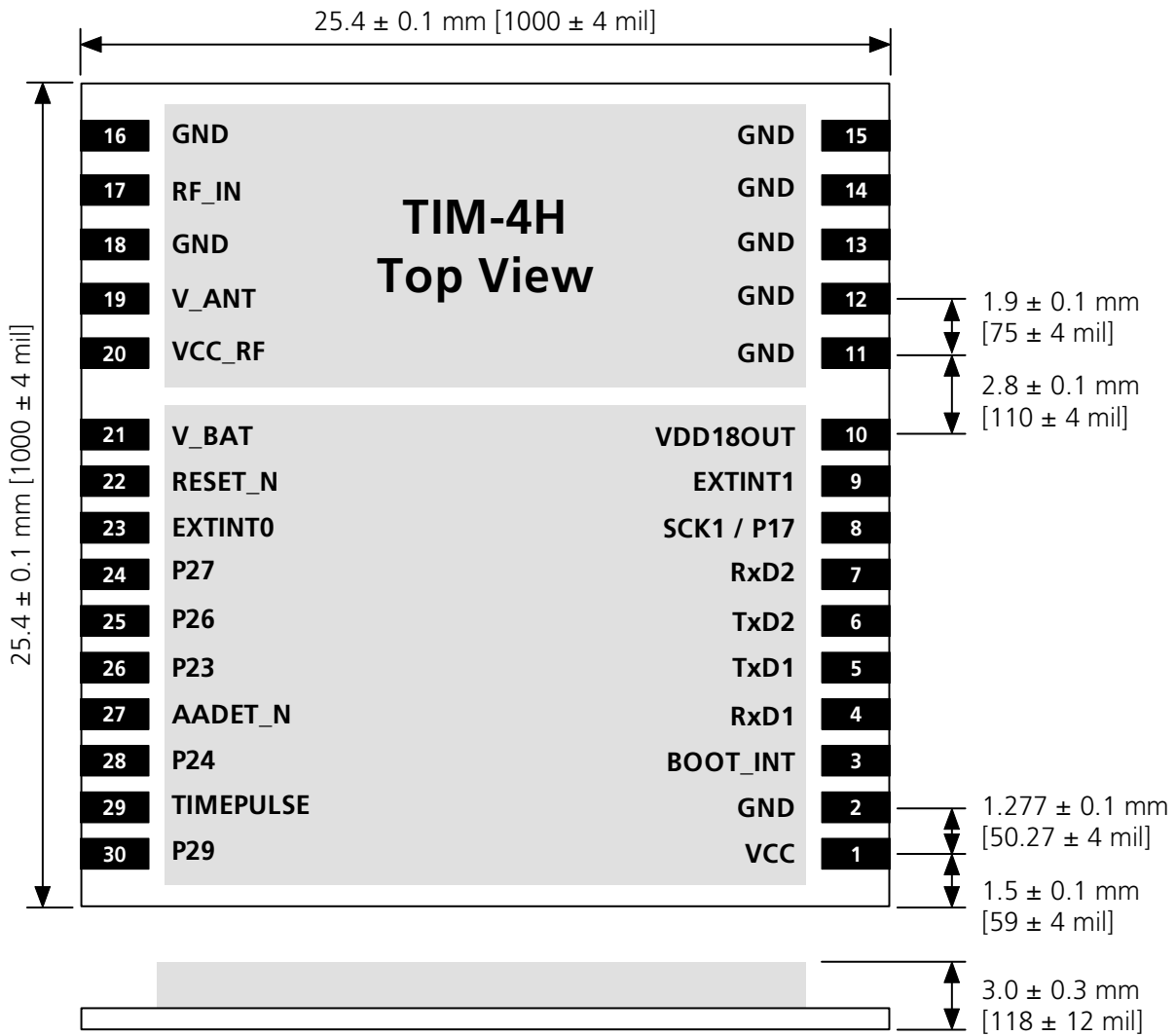

Figure 2: TIM-4H Dimensions

3.2 Specification

Parameter	Specification	Tolerance	Unit
Length	25.4	±0.1	mm
Width	25.4	±0.1	mm
Thickness	3.0	±0.3	mm
Pitch RF pins	1.9	±0.1	mm
Pitch Digital pins	1.277	±0.1	mm
Weight	3		g

Table 6: Mechanical Specification

3.3 Pin Assignment

Standard Function				Alternative Functions ⁹			Remarks
No	Name	I/O	Description	Name	I/O	Description	
1	VCC	I	Supply voltage				
2	GND	I	Ground				
3	BOOT_INT	I	Boot mode				Internal pull-down
4	RxD1	I	Serial Port 1				Internal pull-up
5	TxD1	O	Serial Port 1				
6	TxD2	O	Serial Port 2				
7	RxD2	I	Serial Port 2				Internal pull-up
8	-	I	(Not assigned)	SCK1 P17	I/O I/O	Serial Clock 1 GPIO	Internal pull-down
9	EXTINT1	I	External Interrupt Pin	P13	I/O	GPIO	Internal pull-up
10	VDD18OUT	O	1.8V output				
11 – 16	GND	I	Ground				
17	RF_IN	I	GPS signal input				Apply no DC through this pin
18	GND	I	Ground				
19	V_ANT	I	Antenna Bias voltage				
20	VCC_RF	O	Output Voltage RF section				
21	V_BAT	I	Backup voltage supply				
22	RESET_N	I/O	Reset				Open drain, do not drive high
23	EXTINT0	I	External Interrupt Pin	P9	I/O	GPIO	Internal pull-up
24	-	I	(Not assigned)	P27	I/O	GPIO	Default configuration: Input, internal pull-up
25	-	I	(Not assigned)	P26	I/O	GPIO	Default configuration: Input, internal pull-up
26	-	I	(Not assigned)	P23	I/O	GPIO	Default configuration: Input, internal pull-up
27	AADET_N	I	Active Antenna Detect	P14	I/O	GPIO	Default configuration: Input, internal pull-down
28	-	I	(Not assigned)	P24	I/O	GPIO	Default configuration: Input, internal pull-up
29	TIMEPULSE	O	Time pulse (1PPS)	SCK2	I/O	Serial Clock 2	
30	-	I	(Not assigned)	P29	I/O	GPIO	Default configuration: Input, internal pull-up

Table 7: Signals and Module Interface

For more information see the *System Integration Manual for ANTARIS 4* [1].

⁹ ANTARIS™ Software Customization Kit needed to explore alternate functions. The SPI (available on the TIM-LP, -LF and -LL) is not supported in the TIM-4P.

4 Electrical Specification

4.1 Absolute Maximum Ratings

Parameter	Symbol	Min	Max	Units
Power Supply				
Power supply voltage (VCC)	Vcc	-0.3	3.6	V
Backup battery voltage (V_BAT)	Vbat	-0.3	3.6	V
Input Pins				
Input pin voltage (all except RESET_N)	Vin	-0.3	5	V
Input pin voltage of RESET_N	Vin_reset	-0.3	1.95	V
Voltage Supply output for Active Antenna and RF Section				
VCC_RF output current	Iccrf		50	mA
RF Input				
Antenna bias voltage (applied via V_ANT)	Vant	0	6	V
Antenna bias current (applied via V_ANT)	Iant		100	mA
Input power at RF_IN (source impedance 50Ω, continuous wave)	Prfin		-5	dBm
Environment				
Storage temperature	Tstg	-40	125	°C

Table 8: Absolute Maximum Ratings

- ! Warning** Stressing the device beyond the “Absolute Maximum Ratings” may cause permanent damage. These are stress ratings only. The product is not protected against overvoltage or reversed voltages. If necessary, voltage spikes exceeding the power supply voltage specification, given in table above, must be limited to values within the specified boundaries by using appropriate protection diodes.

4.2 Operating Conditions

Parameter ¹⁰	Symbol	Condition	Min	Typ	Max	Units
Power Supply						
Power supply voltage	Vcc		2.7		3.3	V
Power supply voltage ripple	Vcc_PP				50	mV
Sustained supply current ¹¹	Icc	Vcc = 3.0 V		39		mA
Peak supply current ¹²	Iccp	Vcc = 3.3 V			70	mA
Sleep mode current	Iccs	Vcc = 3.0 V		80		μA
Backup battery voltage	Vbat		1.5		3.6	V
Backup battery current	Ibat	Vbat = 3.3 V		5		μA
1.8V output voltage (VDD18OUT pin)	Vdd18out		1.65	1.8	1.95	V
1.8V output current (VDD18OUT pin)	Idd18out				30	mA
UART and all I/O Signals¹³						
Input pin voltage range	Vin		0		5	V
Input pin low voltage	Vin_low				0.41	V
Input pin high voltage	Vin_high		1.46			V
Output pin voltage range	Vout		0		VCC	V
Output pin low voltage	Vout_low	Iout = 0.3 mA			0.1	V
Output pin high voltage	Vout_high	Iout = 0.3 mA	VCC-0.1			V
RESET_N Input (Open-Drain I/O)						
Input and output pin voltage range	VinR		0		1.8	V
Input pin low voltage	Vin_lowR				0.46	V
Input pin high voltage	Vin_highR		1.3			V
Output pin low voltage	Vout_lowR	Iout = 0.3 mA			0.1	V
Output pin high voltage	Vout_highR	Iout = 0.1 mA	VDD18OUT -0.2			V
RF input						
Antenna gain	Gant				50	dB
V_ANT antenna bias voltage (must connect to ground if not used)	Vant		2		6	V
Antenna bias voltage drop	Vant_drop	Iant=10mA		20	50	mV
VCC_RF voltage	Vccrf			Vcc - 0.1		V
VCC_RF output current	Iccrf			20	50	mA
Environment						
Operating temperature	Topr		-40		85	°C

Table 9: Operating Conditions

Operation beyond the "Operating Conditions" is not recommended and extended exposure beyond the "Operating Conditions" may affect device reliability.

¹⁰ All specification are at an ambient temperature of 25°C.

¹¹ Average current drawn during Continuous Tracking Mode with 1 Hz update rate, using 9 channels for tracking and navigation and 3 channels for searching satellites (= acquisition). Use this figure to determine required battery capacity.

¹² Peak current drawn during initial acquisition phase. Use this figure to dimension maximum current capability of power supply.

¹³ RxD1, RxD2, EXTINT0 and EXTINT1 provide internal pull-up to V_BAT18 (Battery supply regulated to 1.8V) and not VCC.

5 Environmental Specification

Detailed description of the test series:

Test		Standard
Visual inspection		IPC-A-610 "Acceptability of electronic assemblies" I.T.R.I. Publication No. 700 IPC-SM-840B Class 2.
Thermal shock	-40°C...+125°C, 100 cycles	IEC 68-2-14
Function at various temperatures	-40°C/2 hours; RT/2 hours; +85°C/2 hours; function tests at stable temperature	IEC 68-2-1 and IEC 68-2-2
Lifespan test	+85°C/1000 hours, in function	IEC 68-2-2
Damp heat, cyclic	+25°C...+55°C; >90% rH	IEC 68-2-30
Vibration	10-500 Hz; 2 hours/axis; 5g	IEC 68-2-6
Shock	30g/11ms (half sine); 3 Shock/axis; no function	IEC 68-2-27
Metallographic investigations		IPC-QE-650

Note: This specification is preliminary and yet subject to confirmation.

Table 10: Environmental Specification

6 Product Lineup

6.1 Default Settings

Please refer to the *System Integration Manual for ANTARIS 4* [1] for information about further settings.

Interface	Settings
Serial Port 1 Output	9600 Baud, 8 bits, no parity bit, 1 stop bit Configured to transmit both NMEA and UBX protocols, but only following NMEA and no UBX messages have been activated at start-up: GGA, GLL, GSA, GSV, RMC, VTG, ZDA, TXT Additional messages can be activated with appropriate input messages.
Serial Port 1 Input	9600 Baud, 8 bits, no parity bit, 1 stop bit, Autobauding disabled Automatically accepts following protocols without need of explicit configuration: UBX, NMEA, RTCM The GPS receiver supports interleaved UBX and NMEA messages.
Serial Port 2 Output	57600 Baud, 8 bits, no parity bit, 1 stop bit Configured to transmit both NMEA and UBX protocols, but only following UBX and no NMEA messages have been activated at start-up: NAV-POSLH, NAV-SOL, NAV-SVINFO, NAV-STATUS MON-IO, MON-SCHD, MON-TXBUF, INF-Warning, INF-Error, INF-Notice Additional messages can be activated with appropriate input messages.
Serial Port 2 Input	57600 Baud, 8 bits, no parity bit, 1 stop bit, Autobauding disabled Automatically accepts following protocols without need of explicit configuration: UBX, NMEA, RTCM The GPS receiver supports interleaved UBX and NMEA messages.
TIMEPULSE	1 pulse per second, synchronized at rising edge, pulse length 100ms

Table 11: Available Protocols

6.2 Ordering Information

Ordering No.	Product
TIM-4H-0-000-0	TIM-4H Programmable GPS Module with SuperSense <u>Delivery Packing</u> 0 = Single samples 1 = Tape on reel (100 pieces)

Table 12: Ordering Information

Parts of this product are patent protected.

Related Documents

- [1] System Integration Manual for ANTARIS 4, Docu. No GPS.G4-MS4-05007
- [2] ANTARIS 4 Protocol Specification, Docu. No GPS.G3-X-03002

All these documents are available on our homepage (<http://www.u-blox.com>).

Contact

For further info, please contact us:

Headquarters

u-blox AG

Zuercherstrasse 68
CH-8800 Thalwil
Switzerland

Phone: +41 44 722 74 44
Fax: +41 44 722 74 47
E-mail: info@u-blox.com

www.u-blox.com

Sales Offices

North, Central and South America

u-blox America, Inc.

13800 Coppermine Road
Herndon, VA 20171
USA

Phone: +1 (703) 234 5290
Fax: +1 (703) 234 5770
E-mail: info_us@u-blox.com

Regional Office West Coast:

8600 Lemon Ave #1
La Mesa, CA 91941
USA

Phone: +1 (619) 741 3011
Fax: +1 (619) 741 4334
E-mail: info_us@u-blox.com

Technical Support:

Phone: +1 (703) 234 5290
E-mail: support_us@u-blox.com

Europe, Middle East, Africa

u-blox AG

Zuercherstrasse 68
CH-8800 Thalwil
Switzerland

Phone: +41 44 722 74 77
Fax: +41 44 722 74 47
E-mail: info@u-blox.com

Technical Support:

Phone: +41 44 722 74 74
E-mail: support@u-blox.com

Asia, Australia, Pacific

u-blox Asia Pacific Ltd.

435 Orchard Road
#19-02, Wisma Atria,
Singapore 238877

Phone: +65 6734 3811
Fax: +65 6736 1533
E-mail: info_ap@u-blox.com

Regional Office Korea:

1258 Ho, Shinhan MetroKhan
#1115, BisanDong
DongAn-Ku
Anyang-si
KyungKi-do, Korea

Phone: +82 11 1708 2584
Fax: +65 6736 1533
E-mail: info_ap@u-blox.com

Regional Office China:

Room 716-718
No. 65 Fuxing Road
Beijing, 100036, China

Phone: +86 1390 1163 970
Fax: +65 6736 1533
E-mail: info_ap@u-blox.com

Technical Support:

Phone: +65 6734 3811
E-mail: support_ap@u-blox.com